



## MANUAL FOR USE AND MAINTENANCE

- S3
- S5
- COMPACT
- NEW
- RAPID
- SPAZIO



LSC 001 -UK- REV. 06

# CONFORMITY DECLARATION

MANUFACTURER: **La Spaziale SpA**

ADDRESS: **Via E. Duse, 8 - Casalecchio di Reno (BO) ITALY**

## HEREBY DECLARES THAT:

The espresso coffee machines from the following ranges: **New, Rapid, Spazio, S3, S5, Compact**, conform to the directions in the following DIRECTIVES:

**2004/108/EC (Electromagnetic Compatibility Directive) with application of the following (parts/ clauses) from harmonized standards:**

- **EMISSION: EN 55014-1 + EN 61000-3-2 + EN 61000-3-3**
- **IMMUNITY: EN 55014-2**

**2006/95/EC (Low Voltage Directive) with application of the following (parts/clauses) from harmonized standards:**

- **EN 60335-1**
- **EN 60335-2-75**
- **IEC 60335-2-75**

---

## **EC Declaration of Conformity to the Directive 97/23/EC Pressurised Equipment Directive –PED**

MANUFACTURER: **La Spaziale SpA**

ADDRESS: **Via E. Duse, 8 - Casalecchio di Reno (BO) ITALY**

## HEREBY DECLARES THAT:

On espresso coffee machines from the following ranges: **New, Rapid, Spazio, S3, S5, Compact**,

The overall pressure is composed of a boiler complete with safety and adjustment devices, used for rapid preparation of espresso coffee, steam and infusions.

**This assembly conforms to the essential requirements of the Directive 97/23/EC and to national laws acknowledging it , following the conformity assessment procedure below:**

- **UNI 9887 Regulations, ISPESL collection rev. 95**

The assembly also satisfies the following EC Directives:

- **2006/42/EC - 2006/95/EC - 2004/108/EC**



Franca Cacciari (CEO)



---

**CONTENTS**

---

<b>Chap. 1</b>	<b>GENERAL NOTES .....</b>	<b>pag. 4</b>
1.1	RATING PLATES.....	4
1.2	GENERAL WARNINGS .....	4
1.3	MACHINE EQUIPMENT .....	5
1.4	SAFETY RULES .....	5
1.5	INSTALLATION REQUIREMENTS FOR THE USER.....	6
<b>Chap. 2</b>	<b>STARTING UP AND PROGRAMMING THE APPLIANCE</b>	
	<b>(Range New - Rapid - Spazio - S3 EP/EK models - S5 – Compact models) .....</b>	<b>pag. 7</b>
2.1	STARTING UP.....	7
2.2	ALARMS CONTROL.....	12
2.3	ROUTINE APPLIANCE MAINTENANCE TO BE PERFORMED BY THE USER.....	14
2.4	HOW TO CLEAN THE MILK – SENSOR .....	15
<b>Chap. 3</b>	<b>STARTING UP AND PROGRAMMING THE APPLIANCE</b>	
	<b>(Range S3 Seletron Model).....</b>	<b>pag. 18</b>
3.1	STARTING UP .....	18
3.2	ALARMS CONTROL.....	24
3.3	ROUTINE APPLIANCE MAINTENANCE TO BE PERFORMED BY THE USER.....	26
<b>Chap. 4</b>	<b>PARTS.....</b>	<b>pag. 27</b>

1.1 RATING PLATES

 Espresso machines  P.S. 0,6 MPa max	La Spaziale S.p.A. - MADE IN ITALY - via E. Duse, 8 (UCIMAC) 40033 Casalecchio di Reno BOLOGNA
	SERIAL NO. 2006 MOD. VOLT Hz WATT IPX2 BOILER Lt. 0,15 MPa

	- MADE IN ITALY - ( UCIMAC ) - CASALECCHIO DI RENO (BO) -
GAS PRESSURE	G 110 = 8 mbar
CATEGORY III	G 20 = 18 mbar
TYPE A	G 30 = 30 mbar
BURNER POWER kW	

The rating plate of the appliance is located in the area below the drip tray (9). To have access to the rating plate, switch the appliance off using the main switch (3) and then remove the drip tray (9).

1.2 GENERAL WARNINGS

 **WARNING!**  
 The electric system, water supply system, drainage system and gas system (in case the appliance is pre-fitted for gas), **MUST** already be put in place by the customer in order to allow the proper installation of the machine. The installation engineer cannot change the existing system put in place by the customer. See chapter 1.5: "Arrangements for installation provided by the customer".

 **WARNING!**  
 The appliance must be installed where use and maintenance are restricted to trained staff.

 **Disposal of the equipment by the users within the European Community ( WEEE) in compliance with the article 13 of the legislative decree issued on 25 July 2005, nr151 "Implementation of the directives 2002/95/CE,2002/96/CE and 2003/108/CE, concerning the decrease in the usage of dangerous substances in the electrical and electronic equipment and the disposal of waste".**

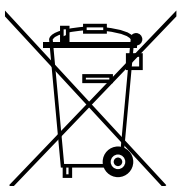

The symbol of the crossed waste bin indicated on the equipment or on the packaging means that the product at the end of its lifetime must be disposed of separately from all the other waste.

The separate collection of this equipment coming at the end of its lifetime is organized and run by the importer/distributor. The user who should have to dispose of such equipment should get in touch with the importer/ distributor and follow the procedure they have adopted for the separate disposal of the equipment coming at the end of its lifetime.

The proper separate disposal of disused equipment so that it can be recycled and treated according to what is environmentally compatible contributes to avoid possible negative effects on the Environment and on Health and allows the reutilization and/or the recycling of the materials the equipment is composed of.

The improper disposal by the user causes the enforcement of the administrative sanctions according to current regulations.

### 1.3 MACHINE EQUIPMENT

<b>A</b>	1 set of filter holders with relative spouts	<b>E</b>	1 wrench for shower head removal
<b>B</b>	1 complete set of hoses for connection to water mains	<b>F</b>	1 brush
<b>C</b>	2 sets of filters	<b>G</b>	1 motor-driven pump (unless already built in)
<b>D</b>	1 set of shower heads	<b>H</b>	1 manual coffee tamper

### 1.4 SAFETY RULES

 **CAREFULLY READ THE FOLLOWING WARNINGS, WHICH OFFER IMPORTANT GUIDELINES FOR THE SAFE USE AND MAINTENANCE OF THE APPLIANCE.**

The appliance must only be used for its intended purpose and it must be installed in a suitable place for its use. Any other use is therefore considered as improper and unreasonable.

The manufacturer cannot be held liable for any damage caused by improper, incorrect or unreasonable use. Installation must be carried out by qualified personnel according to current laws and to the manufacturer's instructions. Incorrect installation may cause damage to people, animals or property for which the manufacturer cannot be held liable.

 **The electrical safety of the appliance is fully achieved only after it has been correctly connected to an earthing system as required by the laws in force.**

It is necessary to have the earthing connection checked by professionally qualified personnel. The manufacturer cannot be held liable for any damage caused by the lack or inefficiency of the system's earthing connection. The appliance has not been designed for outdoor use. It must only be operated in a place where the ambient temperature is between **+5°C** and **+40°C**.

 **The use of any electrical appliance also requires observance of the following important regulations:**

- Do not touch the appliance with wet or damp hands or feet.
- Do not use the appliance barefooted.
- Do not pull the power supply cord to unplug the appliance from the mains power.
- Do not allow children or unqualified persons to use the appliance.
- Access to the appliance's service area must be restricted to those persons with the relevant practical experience and familiarity with the appliance itself, especially in terms of safety and hygiene.
- Before carrying out any routine maintenance or cleaning operation, disconnect the appliance from the mains power and shut off the water supply tap.
- In the event of damage and/or malfunction of the appliance, switch it off completely without trying to make any direct repairs. Contact the nearest Service Centre authorised by the manufacturer.
- In order to guarantee the proper efficiency and operation of the appliance, it is fundamentally important to follow the manufacturer's instructions, and to follow a regular maintenance schedule.
- The appliance has **IPX2** protection against water and therefore, it cannot be installed in areas where it may be subject to jets of water.
- The appliance has **class I** protection against electric shocks.
- The noise emitted by the appliance during normal operation is less than **70 dB**.
- **NOTE: Appliances fitted to operate with gas system.**  
The appliance has been fitted by the manufacturer to operate with **LPG** under a maximum supply pressure of **30 mbar**. Adaptation to operate with any other type of gas must be carried out by personnel authorised by the manufacturer.

 **Failure to comply with the above regulations could jeopardise the correct operation and safety of the appliance as well as its useful lifetime.**

 **WARNING!**  
The appliance weight is more than **30 kg** and therefore, it cannot be moved by a single person alone.

## 1.5 INSTALLATION REQUIREMENTS FOR THE USER

The machine has to be placed on a stable flat surface that can guarantee a safe position. Check this important requirement, since the manufacturer cannot be considered liable for any damage caused by the instability of the appliance. While preparing the systems, take into account that a hole is needed in the bearing surface in order to make all electric and water connections through the opening below where a water softener will need to be fitted, if recommended by the installation engineer.

A hole of **10 x 10 cm** is enough in the area (a) as indicated in Pict. 1.

The machine needs a minimum clearance of:

- height cm. 60
- width cm. 40
- depth cm. 40

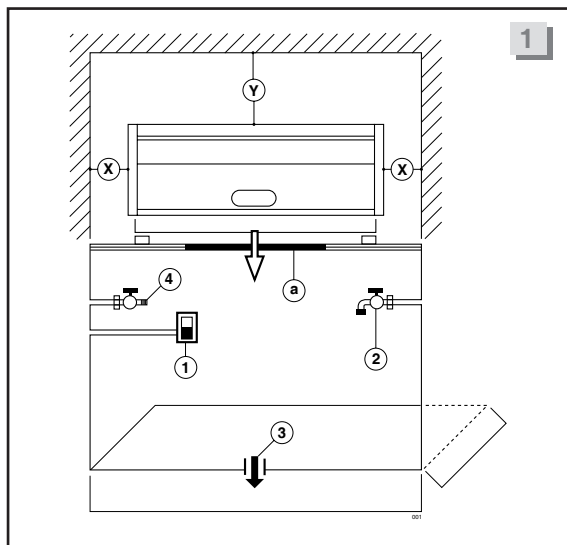

**1** Single pole switch with an opening of at least 3 mm between contacts

**x** min. 20 cm.

**2** Water supply tap

**y** min. 40 cm.

**3** Drain siphon

**z\*** min. 10 cm.

**4** Gas supply tap (if fitted)

\*) Distance between the back of the appliance and the wall.

- Between the water mains and the water inlet pipe of the appliance, there must be a tap to stop the water flow if necessary (2 - Pict.1).

- The water mains pressure must be within the range of **1 and 5 bar**. If this requirement is not met, please consult the manufacturer.

- The appliance is supplied without a plug. It is supposed to be directly connected to the electric mains and therefore, it is necessary to fit a single-pole switch with contact opening of **3 mm** or more beforehand, according to the regulations in force (1 - Pict.1).

- The drainpipe of the appliance must be directly connected to a suitable open drain siphon, previously installed by the customer (3 - Pict.1).

Do not fit the drain pipe into basins or buckets placed under the counter as this will increase the possibility of forming dirt deposits and as a result, the spread of bacteria.

**⚠ WARNING!**

**For appliances operating with gas, the gas supply tap must be fitted in an easily accessible place (4 - Pict.1), so as to be able to shut off the gas supply if necessary.**

**Regularly check the expiry date on the gas pipe connecting the system and the appliance and have it replaced by the Service Centre before this date.**

**⚠ WARNING!**

**The appliance is supplied without water in the boiler. This is to prevent serious damage if the appliance is exposed to low temperatures.**

**The appliance must only be supplied with cold drinking water.**

## STARTING UP AND PROGRAMMING THE APPLIANCE

(Range New - Rapid - Spazio - S3 EP/EK - S5 – Compact models)

 FOLLOW THE INSTRUCTIONS BELOW (REFERRING TO THE LIST OF PARTS ON PAGES 27/34).

### 2.1 STARTING UP

#### FILLING THE BOILER

- a) Open the water supply tap as fitted during the preparatory stages (2 - Pict.1 - page 6).
- b) Make sure that on the pressure gauge of the motor-driven pump (17) you can read the water mains pressure ( approx. 4 bar).
- c) Push the manual filling valve on the appliance (1) until the boiler level indicator is halfway (2).  
In **group 1 - Compact** models and on models from the **Rapid - Spazio** range fitted with additional steam wand, to have access to this tap, it is necessary to remove the drip tray (9). The closing of this tap is manual.

#### SWITCHING ON THE APPLIANCE

Turn on the main switch (1 - Pict.1 - page 6), as described for the preparation of the system, then turn on the appliance switch (3) setting it to **ON/1** and making sure that the electric connection control light (22), where present, switches on.

For the **S5 range**, when the appliance is switched on, the electronic part carries out a check; all symbols on the control panel are switched on from left to right. At the end of this stage, the symbol for the temperature setting will start to flash to indicate that the appliance is heating up.

 **NOTE.** According to the amount of water filled manually, it is possible to use the automatic refill system when the switch (3) is turned on, until the boiler water level indicated by the manufacturer is reached.

#### ELECTRIC SWITCHING ON AND BOILER WATER REFILL

In the **S5 1 GROUP** range, in order to refill the boiler with water , turn on the main switch as arranged in the preparatory stages ( 1-Pict 1- page 6) ,then open the water supply tap ( 2- Pict 1 page 6 ) making sure that the water mains pressure is visualized ( approx 4 bar ) on the pressure gauge of the motor-pump ( 17).

Turn the switch knob of the machine to position 1, the LEDs on the touchpad switch on , indicating that the machine is connected to power , the boiler water refill sets in motion automatically until the boiler water level indicated by the manufacturer is reached.

#### ONLY FOR EQUIPMENT FITTED TO OPERATE WITH GAS (optional)

- a) Open the gas tap mentioned in the preparation of the system (4 - Pict.1 - page 6).
- b) Turn the knob (30) on the machine by 90° until the symbol of the large flame on the knob itself is at the top.
- c) Push the knob (30) and the gas igniter (31) at the same time until the gas turns on; this can be seen through the inspection opening (41).
- d) Hold down the knob (30) for about 10 seconds and check through the special inspection opening (41), that the flame stays lit.
- e) It is recommended to turn the gas adjustment knob (30) to the small flame setting during summer to prevent useless overheating of the coffee cups on the top grid of the machine (14).

## HEATING PHASE AND PRESET PHASE FOR OPERATION (Range New - Rapid - Spazio - S3)

In the S5 1 GROUP range , turn the switch knob to position 2 (boiler heating element ON )

- a) Fasten the filter holders (11) to the delivery groups (16).
- b) Open the steam valves (5) (turning them anticlockwise) and leave them open; then move the steam wands (8) over the grid (10).
- c) Wait for steam to come out of the wands (8) (about **15 / 20 minutes**) then close the steam valves (5) (turning them clockwise).
- d) Wait for the appliance to reach operating temperature, which can be seen on the pressure gauge (4) on the appliance (1 bar pressure).  
On the **Seletron** model it is possible to view the temperature in °C° set during the installation phase being reached on the display (33).

 **NOTE. The operating temperature is the boiler temperature during normal operation.**

- e) The appliance is ready for use.

## HEATING PHASE AND PRESET PHASE FOR OPERATION (Range S5 - Compact)

- a) Fasten the filter holders (11) to the delivery groups (16).
- b) Open the steam valves (5) (moving the lever upwards) and leave them open; then move the steam wands (8) over the grid (10).
- c) Wait for steam to come out of the wands (8) (about **15 / 20 minutes**) then close the steam valves (5) by moving the lever back to its original position.
- d) Wait for the appliance to reach operating temperature, which can be seen on the pressure gauge (4) on the appliance (1 bar pressure). For **S5 range** models, check the control panel (13) to make sure that the temperature set at the time of installation, given in °C, has been reached. During the heating phases, make sure that the symbols on the control panel (13) switch on in progression as the temperature rises. The display will start to show this as soon as the temperature reaches 105 °C and will continue until the appliance reaches its operating temperature (the set temperature symbols will go from flashing to fixed). Each time that the temperature drops to below the SET level, the symbol indicating the operating temperature will start to flash (heating phase) until the set temperature is reached.

 **NOTE. The operating temperature is the boiler temperature during normal operation.**

- e) The appliance is ready for use.

## COFFEE PREPARATION

- a) Remove a filter holder (11/a or 11/b according to whether 1 or 2 cups of coffee are required) from the delivery group (16).
- b) Fill it with ground coffee, taking care not to leave any coffee powder on the top edge of the filter holder. Press down the coffee with the special coffee tamper provided.
- c) Firmly re-attach the filter holder to the group, without tightening it excessively.
- d) Place one or two cups below the filter holder (according to whether it is for 1 or 2 cups of coffee).
- e) Push the button (12) on the delivery group until the required amount of coffee has been delivered, then manually stop the delivery function by pressing the same button again.
- f) For **EK** and **Seletron** models, it is sufficient to press any of the coffee delivery buttons (25-26-27-28) with pre-set doses (set during installation) or alternatively, to use the manual delivery button (29).

 **NOTE. To stop coffee delivery earlier after using one of the buttons with pre-set doses, just press the button (29) on the same touchpad (except for range Super 3000 Seletron model).**



### DISPENSING STEAM FOR HOT DRINK PREPARATION (Range New - Rapid - Spazio - S3)

- a) Insert the steam wand (8) into the pitcher containing the drink to be heated up.
- b) Turn the knob (5) of the corresponding steam wand (8) anti-clockwise. Set the amount of steam as needed by turning the knob (5) more or less.
- c) Once the heating phase is finished, stop delivering steam by turning the knob (5) clockwise, remove the steam wand from the pitcher and clean it immediately with a wet sponge, removing all residues of the heated drink.

 **Do not turn the knob (5) to deliver steam before inserting the steam wand (8) into the pitcher in order to prevent possible burns.**

### DISPENSING STEAM FOR HOT DRINK PREPARATION (Range S5 - Compact)

- a) Insert the steam wand (8) into the pitcher containing the drink to be heated up.
- b) Move the lever (5) of the corresponding steam wand (8) upwards. Set the amount of steam as needed.
- c) Once the heating phase is finished, stop delivering steam by moving the lever (5) to its initial position, remove the steam wand from the pitcher and clean it immediately with a wet sponge, removing all residues of the heated drink.

 **Do not move the lever (5) to deliver steam before inserting the steam wand (8) into the pitcher, in order to prevent possible burns.**

### POURING HOT WATER FOR PREPARING INFUSIONS (Range New - Rapid - Spazio - S5 - Compact)

- a) Place the pitcher underneath the hot water spout (7).
- b) Turn on the tap by turning the knob (6) in order to obtain the required amount of water.
- c) Turn off the tap to stop delivering water by setting the knob (6) to its initial position.

 **Do not use the knob (6) to deliver hot water before placing the pitcher below the hot water spout (7), to prevent possible burns.**

### TIMED HOT WATER POURING FOR PREPARING INFUSIONS - A.T. - (Range S5) (optional)

- a) Place the pitcher underneath the hot water spout (7).
- b) Press the button for timed hot water delivery (42).
- c) The water will be delivered for the time set when the machine was installed.

 **NOTE. Do not press the button for timed hot water delivery (42) before placing the pitcher below the hot water spout (7), in order to prevent possible burns.**

### POURING HOT WATER FOR PREPARING INFUSIONS (Range S3 EP model)

- Place the pitcher underneath the hot water spout (7).
- Press the hot water delivery button (6).
- Press the hot water delivering button (6) again to stop delivery water.

**⚠ Do not press the hot water delivery button (6) before placing the pitcher underneath the hot water spout (7), in order to prevent possible burns.**

### POURING HOT WATER FOR PREPARING INFUSIONS (Range S3 EK model)

- Place the pitcher underneath the hot water spout (7).
- Press the hot water delivery button (6).
- The water will be delivered for the time set when the machine was installed.

**⚠ Do not press the timed hot water delivery button (6) before placing the pitcher underneath the hot water spout (7), in order to prevent possible burns.**

### ELECTRIC CUP WARMER (Range S3 and S5 / EK –EP models) (optional) (Range S3 / Seletron model) (standard)

For those appliances fitted with this feature, it is possible to an additional heating for the cups. This is done by using the additional electric cup warmer. Press the cup warmer operating button (24) and check its operating status through the lighting up of the LED/symbol (23) on the control panel (13). To switch it off, press the same button.

### ELECTRIC CUP WARMER (Range New - Rapid - Spazio - Compact) (optional)

For those appliances fitted with this feature, it is possible to have additional heating for the cups. To turn it on, move the main switch (3) from position **1** (standard operating phases) to position **2**. To switch it off, move it back to position **1**.

**⚠ WARNING!**  
It is allowed to place cups on the special cup grid (14) on the top of the appliance as long as the cups have their openings facing upwards (Pict. 2). This is in order to prevent that the combustion fumes of the gas burner, on machines fitted with gas system may come into contact with the inside of the cups, which are supposed to contain coffee.

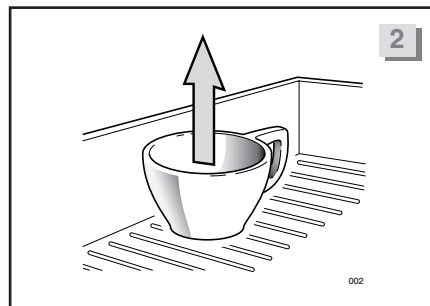

### TEMPORARY TEMPERATURE INCREASE FUNCTION (Range S5)

When the appliance is used in conditions where its temperature could be lowered quite notably, holding down the button  (37) for about 5 seconds will increase the boiler temperature by 2 °C. In this condition, the programmed SET temperature will continue to flash on the control panel (13) and at the same time, the temperature symbol, 2° C above the programmed SET temperature will begin to flash (e.g., if the SET temperature is 120°C, this will begin to flash and continue to do so, while 122°C will begin to flash).

The new SET will follow the progress of the temperature, flashing when the appliance is heating up and fixed when the set temperature has been reached.

To return to the initial status, press the button  (38) for about 5 seconds.

### AUTOMATIC SYSTEM WITH MILK EMULSION WITH ADJUSTABLE TEMPERATURE - M.A.T. (Range S5) (optional)

Appliances fitted with this system can foam milk completely automatically.

- a) Insert the steam wand complete with temperature sensor (45) into the pitcher of milk.
- b) Press the automatic steam dispensing button for milk (44).
- c) The steam will stop automatically as soon as the temperature set during installation has been reached.
- d) When the milk has been foamed, remove the pitcher and use a damp sponge to clean all milk residues from the steam wand with temperature sensor (45).

 **NOTE. Do not press the automatic steam delivery button for milk foaming (44) before inserting the steam wand with temperature sensor (45) into the pitcher, in order to prevent possible burns.**

To adjust milk foaming, use the regulator (46) located on the back of the front panel, next to the steam wand with temperature sensor (45).

Turn the adjustment screw anticlockwise to increase foaming.

Turn the adjustment screw clockwise to reduce foaming.



#### **WARNING!**

**When adjusting the milk foaming level, take care not to touch the steam wand with temperature sensor (45) or wear protective gloves, to prevent possible burns.**

## 2.2 ALARMS CONTROL

### RANGE NEW - EK MODEL

This model informs users as to possible malfunctions through the LEDs for the 4 preset dose buttons on the touchpads.

**1. LED CORRESPONDING TO THE COFFEE DOSE BUTTON DISPENSING, FLASHING AFTER 5-6 SECONDS:**

- Coffee ground too finely.
- Missing reading of the pulses sent by the flow meter to the delivery group.

After checking the grinding fineness, if the problem continues, contact an authorised Service Centre.

**2. ALL LEDS CORRESPONDING TO ALL DOSES ON ALL TOUCHPADS FLASHING:**

- The automatic refill system for the boiler has been in operation for longer than 4 minutes (total block of all machine functions). To return to the standard operating phase, switch the machine off using the main ON/OFF switch (3). If this problem is repeated frequently occurs, switch off the appliance and contact an authorised Service Centre.

### RANGE S3 EK MODEL

This model informs users as to possible malfunctions through the LEDs on the control panel (13).

**Water refill system failure (21-19 lit and 20-18 flashing)**

This alarm is a blocking one and is viewed when the automatic refill system for the boiler has been operating for longer than **4 minutes**. To return to the standard operating phase, switch the appliance off for a second using the ON/OFF switch (3); if the problem persists, switch off the appliance and contact an authorised Service Centre.

**Flow meter failure (the LED corresponding to the delivery group is flashing after 5 seconds)**

This alarm is viewed when, during the delivery phase, there is a flow meter malfunction for the delivery group, or if the coffee has been too finely ground. After checking the grinding fineness, if the problem continues, contact an authorised Service Centre.

**Transformer failure (20-18 lit and 21-19 flashing)**

This alarm is a blocking one and is viewed when no power (24V) is taken on the transformer secondary, which is feeding the solenoid valves of the groups and the automatic boiler refill. Contact an authorised Service Centre.

**Stop on P5 (LED corresponding to the dispensing unit lit)**

This alarm is viewed when coffee deliveries are carried out with the manual delivery button “ON/OFF” (29) and this has been in operation for longer than **4 minutes**. To cancel the alarm, press the button “ON/OFF” (29) again.

**Data loss (21-18 lit and 20-19 flashing)**

This alarm is viewed when the data preset by the operator are lost and default data are reset. To cancel the alarm, press the cup warmer operating button (24). If the problem continues, contact an authorised Service Centre.

### RANGE S5

The appliances of this range of inform users as to possible malfunctions through symbols on the control panel and touchpads.

**1. LED CORRESPONDING TO THE COFFEE DOSE BEING DELIVERED FLASHING AFTER 5-6 SECONDS (EK model only):**

- Coffee ground too finely.
- Missing reading of the pulses sent by the flow meter to the delivery group.

After checking the grinding fineness, if the problem continues, contact an authorised Service Centre.

**2. ALL DOSE SYMBOLS ON ALL TOUCHPADS FLASHING AND TEMPERATURE SYMBOLS SWITCHED OFF:**

- The automatic refill system for the boiler has been operating for longer than 3 minutes (total block of all machine operations).

**3. "125 °C" SYMBOL LIT AND ALL OTHER SYMBOLS SWITCHED OFF:**

- When the temperature taken by the sensor is above **140 °C** (total block of all machine operations). To return to normal operation, turn off the machine with the ON/OFF switch (3). If the problem persists, switch off the appliance and contact an authorised Assistance Centre.

**4. "105 °C" SYMBOL LIT AND ALL OTHER SYMBOLS SWITCHED OFF:**

- When, **20 minutes** after switching on, the temperature taken by the sensor is less than **60 °C** (total block of all machine operations). To return to normal operation, turn off the machine with the ON/OFF switch (3). If the problem persists, switch off the appliance and contact an authorised Assistance Centre.

**5. ALL TEMPERATURE SYMBOLS FLASHING AND ALL TOUCHPAD SYMBOLS SWITCHED OFF:**

- There is a temperature sensor short circuit or interruption (total block of all machine operations). Switch off the appliance and contact an authorised Assistance Centre.

**6. M.A.T. SYSTEM DELIVERY BUTTON SYMBOL SWITCHED OFF (only if present):**

- M.A.T. temperature probe short circuit or failure. Contact an authorised Assistance Centre.



**NOTE.** When this alarm condition occurs, it is still possible to foam milk automatically by holding down the M.A.T. delivery button (44) until the required temperature is reached. When the button is released, steam delivery will stop.

**7. TECHNICAL ASSISTANCE SYMBOL LIT**

*(only if SERVICE management has been set by the Technical Assistance):*

- This means the number of pre-set solenoid valve action cycles has reached the set alarm threshold. Contact an authorised Assistance Centre.

**8. TECHNICAL ASSISTANCE SYMBOL FLASHING**

*(only if FILTER management has been set by the Technical Assistance):*

- This means the number of pre-filled litres for the softener has reached the set alarm threshold. Contact an authorised Assistance Centre.

**RANGE COMPACT - EP MODEL**

This model informs users as to possible malfunctions through symbols on the touchpads.

**TOUCHPAD SYMBOLS FLASHING ALTERNATELY:**

- The automatic refill system for the boiler has been operating for longer than 3 minutes (total block of all machine operations). To return to normal operation, turn off the machine with the ON/OFF button. If the problem persists, switch off the appliance and contact an authorised Assistance Centre.

**RANGE COMPACT - EK MODEL**

This model informs users as to possible malfunctions through symbols on the touchpads.

**1. LED CORRESPONDING TO THE COFFEE DOSE BEING DELIVERED, FLASHING AFTER 5-6 SECONDS:**

- Coffee ground too finely.
- Missing reading of the pulses sent by the flow meter to the delivery group.

After checking the grinding fineness, if the problem continues, contact an authorised Service Centre.

**2. ALL DOSE SYMBOLS ON ALL TOUCHPADS FLASHING AND TEMPERATURE SYMBOLS SWITCHED OFF:**

- The automatic refill system for the boiler has been operating for longer than **3 minutes** (total block of all machine all machine operations). To return to normal operation, turn off the machine for a second with the ON/OFF button. If the problem persists, switch off the appliance and contact an authorised Assistance Centre.

## 2.3 ROUTINE APPLIANCE MAINTENANCE TO BE PERFORMED BY THE USER

 **NOTE.** To grant the efficiency of the appliance and to maintain correct operation, it is necessary to follow the manufacturer's instructions as to cleaning and regular maintenance.

 **WARNING!**  
Cleaning and routine maintenance operations must be carried out by the user according to the manufacturer's instructions given here below. Before carrying out any kind of cleaning operation, disconnect the appliance from the electricity mains and from the gas system (if fitted). Cleaning and routine maintenance operations must be carried out when the machine is cold and using protective gloves to prevent abrasions.

### DAILY AT THE END OF THE JOB

#### 1a) Replacing the water in the boiler (**Range New - Rapid - Spazio**).

After turning off the appliance, replace the water in the boiler as follows:

- Place a container that can withstand high temperatures below the hot water nozzle (7) to prevent any hot water spills.
- Turn the hot water knob (6) anticlockwise until the boiler is completely empty, checking the level gauge (2). Refill the boiler immediately using the manual filling button (1).

#### 1b) Replacing the water in the boiler (**Range S3 - EK – EP models**).

- Place a container that can withstand high temperatures under the hot water nozzle (7) to prevent any hot water spills.
- Press and hold down the hot water knob (6) for at least 5 seconds: the automatic boiler emptying cycle will begin (all machine controls are deactivated during this phase). On the **EK** model, the LEDs 18-21 are flashing during this phase while the LEDs 19-20 remain lit.
- At the end of the cycle, the appliance restores the correct water level in the boiler through the automatic refill system. To interrupt this cycle, it is sufficient to hold down the hot water button (6) for about **2 seconds**.
- Disconnect the appliance.

#### 1c) Replacing the water in the boiler (**Range S5 - Compact**).

After turning off the appliance, replace the water in the boiler as follows:

- Place a container that can withstand high temperatures under the hot water nozzle (7) to prevent any hot water spills.
- Open the hot water valve (6), moving the lever upwards until the boiler is completely empty, checking the level indicator (2). Refill the boiler immediately using the manual filling button (1).

#### 1d) Replacing the water in the boiler on appliances with timed water delivery (optional) (**Range S5**).

- Place a container that can withstand high temperatures under the hot water nozzle (7) to prevent any hot water spills.
- Press and hold down timed hot water delivery button (42) for at least 5 seconds: the automatic boiler emptying cycle will begin (all machine controls are deactivated during this phase).
- At the end of the cycle, the appliance will restore the correct water level in the boiler using the automatic filler. To interrupt this cycle, press the hot water delivery button (42).
- Disconnect the appliance.

- 2) Then clean the filter holders and the filters with the brush provided, making sure no dirt is left inside the filter holders and that all filter holes are clean.
- 3) Clean the shower heads below the delivery groups with the brush.
- 4) Clean the drip tray (9) and the cup grid (10), using the standard detergents on sale, if necessary.

### EVERY TWO WEEKS

After turning off the machine, remove the shower heads using the wrench provided; brush them carefully, making sure that all the holes are clean and then refit them following the sequence illustrated in Fig. 3.

- a** Fastening screw
- b** Small shower head
- c** Large shower head
- d** Shower head block
- e** Delivery group

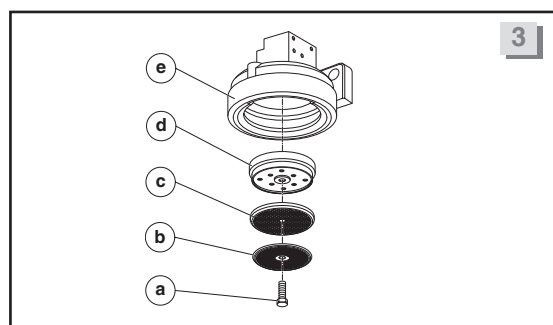

#### WARNING!

Every day, at the end of work and after daily cleaning, turn off the appliance using the electric switch; then close the water supply tap and the gas tap (if fitted) (Fig.1 – page 6).



Do not use water jets to clean the machine.

### WATER SOFTENER

If the installation of a water softener has been recommended by the installation engineer because of hard water and problems of scale deposits, it is necessary to follow the instructions of the water softener's manufacturer (periodic regeneration).

## 2.4 HOW TO CLEAN THE MILK – SENSOR

Clean the milk – sensor every day as follows:

- 1) Unscrew the steamer (1) and dip it in hot water and Pulicaf detergent for 30 minutes (picture below).

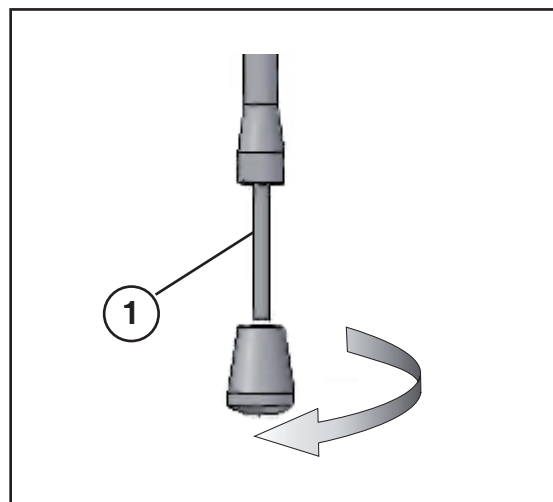

- 2) Unscrew the external tube (2) and dip it in hot water and Pulicaf detergent for 30 minutes (picture below).

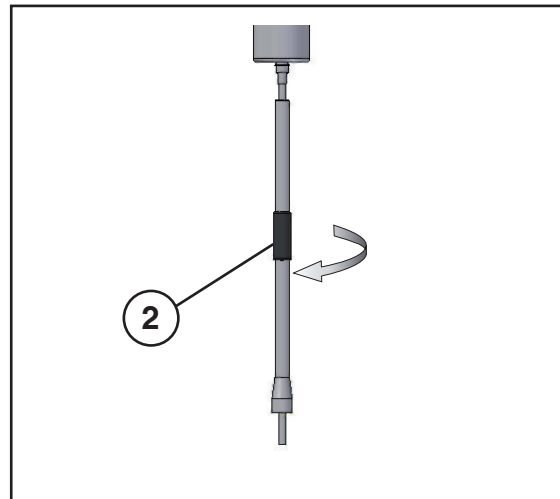

- 3) Unscrew the internal tube (3) (picture below).

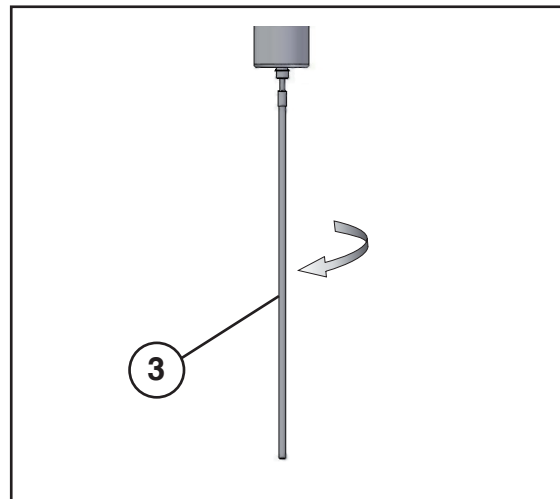

- 4) Dip the internal tube in hot water and Pulicaf detergent for 30 minutes (picture below). In order to remove any milk incrustations, clean the internal part of the sheath by means of the appropriate pipe-cleaner (4) you will find in the machine outfit (picture below).

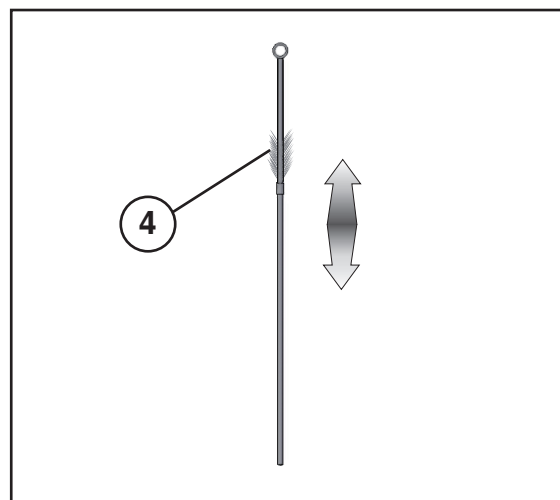



- 5) After cleaning and drying it, reassemble the internal tube (5) and screw it to the end (picture below).

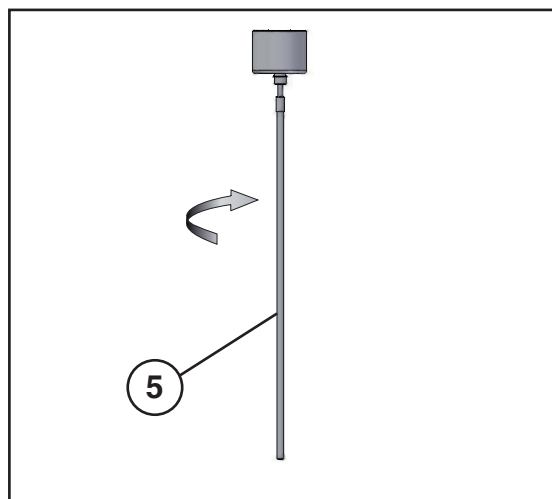

- 6) After cleaning and drying it, reassemble the external tube (6) and screw it to the end (picture below).

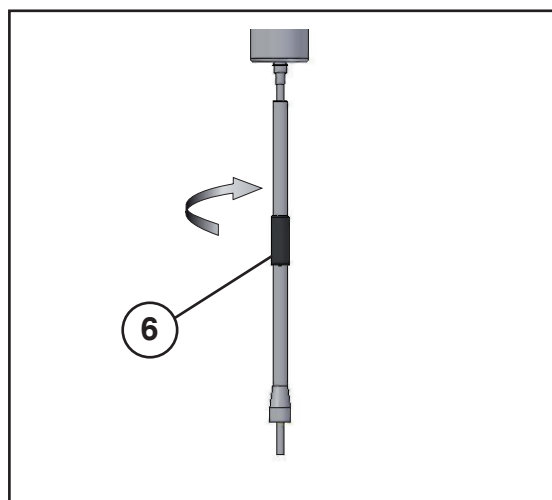

- 7) After cleaning and drying it, reassemble the steamer (7) (picture below).

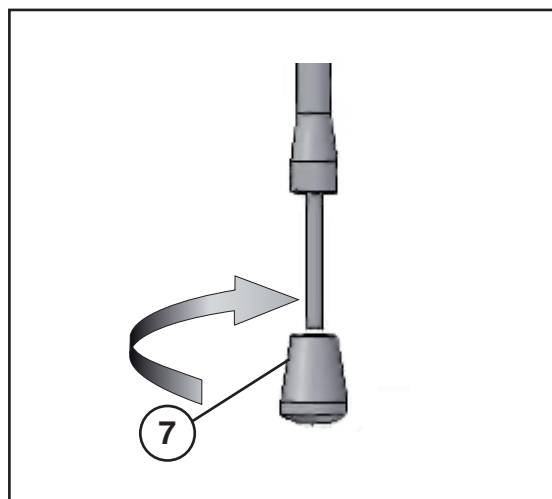

- 8) After the cleaning, push the button of the milk – sensor and check its proper functioning.



**BE CAREFUL !**

Before carrying out any cleaning operations of the milk sensor, switch the machine off. During such operations, wear protective gloves so as to avoid possible burns.

## 3 STARTING UP AND PROGRAMMING THE APPLIANCE (Range S3 - Seletron model)

 FOLLOW THE INSTRUCTIONS BELOW REFERRING TO THE PARTS LIST ON PAGES 27/34.

### 3.1 STARTING UP

#### BOILER WATER FILLING

- a) Turn on the water supply tap, which was fitted during the system pre-arrangement phase (2 - Fig.1 - page 6).
- b) Make sure that the mains water pressure (more or less 4 bar) is shown on the motor-driven pump pressure gauge (17).
- c) Push the knob on the manual filling valve on the appliance (1) downwards until the boiler level indicator is halfway (2).

#### SWITCHING ON THE APPLIANCE ELECTRICALLY

- a) Turn on the main switch (1 -Fig. 1 - page 6), then turn on the appliance switch (3) moving the lever to the **ON** position and making sure that the display (33) switches on.

 **NOTE. According to the amount of water manually filled, it is possible to program the automatic filler system to operate when the switch (3) is turned on and until the correct water level in the boiler for standard operation has been reached.**

#### HEATING PHASE AND PREPARATION OF THE APPLIANCE FOR OPERATION

- a) Attach the filter holders (11) to the delivery groups (16).
- b) Open the steam delivery knobs (5) (by turning them anticlockwise) and leave them open; then move the steam wands (8) over the grid (10).
- c) Wait for steam to come out of the wands (8) (about **15 / 20 minutes**) and then close the steam delivery knobs (5) (by turning them clockwise).
- d) Wait for the appliance to reach the operating temperature, which was preset during installation. The setting in °C can be visualized on the display (33) on the control panel, or alternatively on the pressure gauge (4) (pressure 1 bar) on the appliance.

 **NOTE. The operating temperature is the temperature of the boiler during standard operation.**





















- e) The appliance is ready for use.

#### BASIC SETTINGS

The appliance is supplied with its basic settings already programmed. These are:

- Day of the week
- Time
- Date (day, month, year)

To enter the setting menu for the day of the week, time and date, proceed as follows:

1. Press and hold down the buttons  and  for 5 seconds, until the display reads ““““““A XXXX”””””, where the symbol  is flashing and the symbols “XXXX” refer to the current year (**NOTE. Pressing the two buttons will show the current time of day.**)
2. Change the setting, if necessary, using the buttons  and  and press the button  to confirm.
3. The display will indicate “b XX”, where “XX” indicates the set month. Change the setting, if necessary, using the buttons  and  and press the button  to confirm.
4. The display will indicate “c XX”, where “XX” indicates the set month. Change the setting, if necessary, using the buttons  and  and press the button  to confirm.
5. The display will indicate “DAY X”, where “X” indicates the number of the set day (1 = Monday 2=Tuesday, etc.). Change the setting, if necessary, using the buttons  and  and press the button  to confirm.
6. The display will indicate “d XX:YY”, where “XX” indicates the hour and “YY” the minutes. Change the setting, if necessary, first the flashing “XX” using the buttons  and  and confirming with the button , then change the flashing “YY” using the buttons  and  and confirming with the button , the main view status on the display will then be automatically restored.

## PREPARING COFFEE

- a) Remove a filter holder (11/a or 11/b according to whether it is for 1 or 2 cups of coffee) from the delivery group (16).
- b) Fill it with ground coffee, taking care not to leave any coffee powder on the top edge of the filter holder. Press down the coffee with the special manual coffee tamper provided.
- c) Firmly re-attach the filter holder to the group, without tightening it excessively.
- d) Place one or two cups below the filter holder (according to whether it is for 1 or 2 cups of coffee).
- e) Press one of the coffee delivery buttons (25-26-27-28) corresponding to preset doses or otherwise use the “ON/OFF” button (29) for manual delivery.



**NOTE.** To stop coffee delivery earlier after using one of the buttons with pre-set doses, just press the button (29) on the same touchpad.

## STEAM DELIVERY FOR HOT DRINK PREPARATION

- a) Insert the steam wand (8) into the pitcher containing the drink to be heated up.
- b) Turn the knob (5) of the corresponding steam wand (8) anti-clockwise. Set the amount of steam as needed by turning the knob (5) more or less.
- c) At the end of the heating phase, turn the knob (5) clockwise, remove the steam wand from the pitcher and clean it immediately with a wet sponge, removing all residues of the heated drink.



### WARNING!



**Do not turn the steam knob (5) before inserting the steam wand (8) into the pitcher, in order to prevent possible burns.**

## HOT WATER DELIVERY FOR THE PREPARATION OF TEA, INFUSIONS, ETC.

- a) Place the pitcher below the hot water nozzle (7).
- b) Press the delivery button (6).
- c) Delivery stops after the time programmed during installation.

**WARNING!**  
Do not press the timed hot water delivery button (6) before placing the pitcher beneath the hot water nozzle (7), in order to avoid possible burns.

## ELECTRIC CUP WARMER

For additional heating for the cups, it is possible to use the additional electric cup warmer. Press the cup warmer operating button  and check its operating status through the lighting up of the symbol  on the display (33). To switch it off press the same button.

## TIMED FUNCTION (available with version 8 software)

The appliance can be programmed to show the coffee delivery time, in seconds. This function is used to make sure that delivery time is correct.

**NOTE.** The average time for a coffee dose delivery time is approximately 25-30 seconds. If the delivery time does not fall within this time, use the grinder and doser to adjust the grain size of ground coffee.

To have access to the timer function, proceed as follows:

1. During delivery, press the button , the display will show:

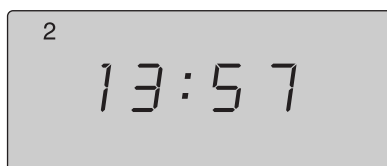

Where "13" indicates the seconds, "57" the tenths of a second and the number "2" indicates the group for which the delivery time is being displayed.

2. Use the buttons  and  to select the group for which to view the timer.

To return to the standard display, press the button  again.

## TIMER FUNCTION



The appliance can be programmed so as to switch on and off automatically at set times on each day of the week.

To program the switching on and off times, proceed as follows:

1. Press and hold down the button **P** about 5 seconds; the display will show the flashing symbol  and "P".
2. Press the button **OK** to enter the **TIMER MENU**; the display will show:











Where "OFF" is visualized by default.

3. If "OFF" is confirmed using the button **OK**, the **TIMER** menu is closed and display returns to showing the flashing symbols  and "P".  
If "ON" is selected with the button , symbol  disappears and, and confirming with the button **OK**, this will open the menu for setting the automatic appliance switching on and off times.  
The display will show:



Where the numbers indicating the switching on time for Monday "DAY 1" will flash as default.

4. Use the buttons  and  to set the hour at which the appliance must switch on and confirm it using the button **OK**.
5. The minutes will start to flash.
6. Use the buttons  and  to set the minutes of the time at which the appliance is to switch on and confirm using the button **OK**.
7. Use the buttons  and  to select the time at which the appliance is to switch off and confirm using the button **OK**.
8. Use the buttons  and  to select the minutes of the time at which the appliance is to switch off and confirm using the button **OK**.
9. The number corresponding to the day of the week is automatically increased; therefore, repeat the operations in steps 4 to 8 to set the switching on and off times for the remaining days.

At the end of the programming phase of the weekly **TIMER**, soon after confirming the switching off time for day no. 7, the display will show the flashing symbols  and "P".

**NOTE.** Every time the minutes for the switching on time are confirmed, the same time is automatically suggested as the switching off time (this is because the switching off time cannot be before the switching on time).

To set the **TIMER** so as not to have a switching on time on a specific day (for example, the day on which the premises are closed) set 00:00 as the switching on time (ON) and 00:00 as the switching off time (OFF).

While the appliance is switched off by the **TIMER**, the display will show:



**NOTE.** If the machine has been switched off by the **TIMER** and it needs to be switched on, press and hold down the button **OK** for around 2 seconds; this will switch on the appliance and deactivate the **TIMER** function (the switching on and off functions will thus become manual). To reset the **TIMER** function, follow the steps described on page 20 (**TIMER FUNCTION**).

## DISPENSING COUNTER MANAGER

To open the menu for the coffee and hot water delivery counters, proceed as follows:

1. Press and hold down the button **OK** for about **4 seconds** until the display indicates:



Where the symbols  are flashing to indicate the partial counters of the cups of coffee delivered by the appliance (coffees delivered using the manual delivery button "ON/OFF" (29) are not counted).

2. To reset the partial counter figures, press and hold down the button **OK** for about **2 seconds** until the display shows "**Reset**".
3. Press the button **OK** to reset the figure.

At this stage, when the button  is pressed, the display will read:





Where the symbols  are now fixed to indicate the total number of cups of coffee delivered by the appliance (coffees delivered using the manual delivery button “ON/OFF” (29) are not counted).

 **NOTE. This is a perpetual counter that cannot be reset to zero.**

Press the button  and the display will show:



Where the flashing symbol  shows the partial counters for the hot water delivered by the appliance.

4. To reset the partial counter figure, press and hold down the button  for about **2 seconds** until the display shows the word “Reset”.
5. Press the button  to reset the figure.

At this stage, press the button  and the display will show:



Where the symbol  is fixed to indicate the total number of hot water doses delivered by the appliance.

**NOTE. This is a perpetual counter that cannot be reset to zero.**

**NOTE. If the appliance is run by timer, the partial counters are automatically reset every time the appliance is switched on by timer.**

**If the figure for the doses delivered exceeds “99999” the display will show, for example:**

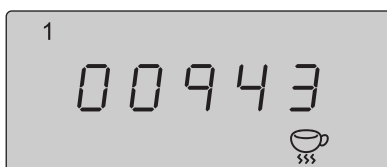

Where the number “1” indicates hundreds of thousands (to be read as 100943).

6. Press the button  to quit the counter menu.

## 3.2 ALARM CONTROL

---

The appliance is run by a program that controls the correct operation of its functions and in case one or more of these is not properly performed, the display will signal the relevant alarm message together with an acoustic signal.

 **NOTE. Messages can be divided into two different types: blocking and non-blocking alarms.**

- Blocking alarms block the appliance completely and to make it work again, it is necessary to switch it off completely and to switch it on again using the main switch (3).
- The non-blocking ones do not block the appliance or its functions and it is necessary to press the button  to cancel them.

### **AL00** Loss of data

This alarm is not a blocking one.

It appears when the main running program of the appliance cannot find the parameters set at installation (temperature and dose settings) in the memory and therefore, the appliance will continue to operate but with default data (standard).

(If this alarm appears, it is necessary to have the appliance reprogrammed by an authorised Service Centre).

### **AL01** High temperature

This alarm is not a blocking one.

It appears when the main running program of the appliance recognises a boiler temperature value that is **5 °C** higher than the preset temperature. If this alarm appears, the static relays are temporarily disconnected.

### **AL02** Temperature probe failure

This alarm is a blocking one.

It appears when the main control program of the appliance recognises that the boiler temperature sensor is not operating within the correct range:

- Temperature lower than **50 °C 20 minutes** after switching on (manual or by timer) or in real time, during normal operation; sensor disconnected
- Temperature higher than **140 °C** (only during normal operation); short circuited sensor (if this alarm appears, call an authorised Service Centre immediately).

### **AL03** Automatic water filling system

This alarm is a blocking one.

It appears when the main control program of the appliance signals that the automatic water filling system has been operating for more than 4 minutes (if the problem persists, switch off the appliance and contact an authorised Service Centre).

### **AL04** Transformer failure

This alarm is a blocking one.

It appears when the main control program of the appliance signals that the power (**24 V**) of the transformer of the solenoid valves is below **13 V** (if this alarm appears, call an authorised Service Centre immediately).



**AL05 Coarse grinding (only if enabled in the relevant menu)**

This is not a blocking alarm.

It appears when the main control program of the appliance signals that the delivery time for a dose corresponding to one of the coffee delivery times is less than the % value set in the relevant menu.

**AL06 Fine grinding (only if enabled in the relevant menu)**

This is not a blocking alarm.

It appears when the main control program of the appliance signals that the delivery time for a dose corresponding to one of the coffee delivery times is more than the % value set in the relevant menu.

**AL07 Counter failure / fine grinding**

This is not a blocking alarm.

It appears when the main control program of the appliance signals that during the setting or the delivery

time of a coffee dose (except those made using the button  ) the relevant flow meter does not send any pulse for water passing through.

(If this alarm appears, check the grinding fineness of the coffee and if the problem is not solved, immediately call an authorised Service Centre).

**AL08 Free-flow delivery time (button  )**

This is not a blocking alarm.

It appears when the main control program of the appliance signals that a delivery group has been continuously operating for longer than **4 minutes**, and therefore it stops it.

### 3.3 ROUTINE APPLIANCE MAINTENANCE TO BE PERFORMED BY THE USER

**NOTE.** To grant efficient equipment and correct operation, it is necessary to follow the manufacturer's instructions carrying out cleaning and routine maintenance.

**WARNING!**  
 Cleaning and routine maintenance operations must be carried out by the user according to the manufacturer's instructions, listed here below. Before carrying out any kind of cleaning operation, disconnect the appliance from the power mains.  
 Cleaning and routine maintenance operations must be performed when the machine is cold and wearing protective gloves to avoid abrasions.  
 Do not use water jets to clean the machine.

#### DAILY AT THE END OF WORK

To refill the water in the boiler, proceed as follows:

- Place a container that can withstand high temperatures below the hot water nozzle (7) to prevent any hot water spills.
- Press and hold down the hot water button (6) for 3 seconds: the automatic boiler emptying cycle will begin (all machine controls are deactivated during this phase).
- At the end of the cycle, the appliance restores the correct water level in the boiler through the automatic refill system.
- Disconnect the appliance and clean the filter holders and the filters with the brush provided, making sure no dirt is left inside the filter holders and that all filter holes are clean.
- Clean the shower heads below the delivery groups with the brush.
- Clean the drip tray (9) and the cup grid (10), using standard detergents, if necessary.

#### EVERY TWO WEEKS

After turning off the machine, remove the shower heads using the wrench provided; brush them carefully, making sure that all the holes are clean and then refit them following the sequence illustrated in Pict. 4.

- a** Fastening screw
- b** Small shower head
- c** Large shower head
- d** Shower head block
- e** Delivery group

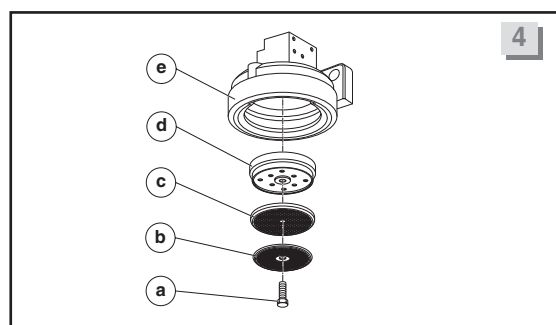

**WARNING!**  
 Every day, at the end of work and after daily cleaning, turn off the appliance using the main switch; then turn off the water supply tap (Pict.1 — page 6).

1 GROUP

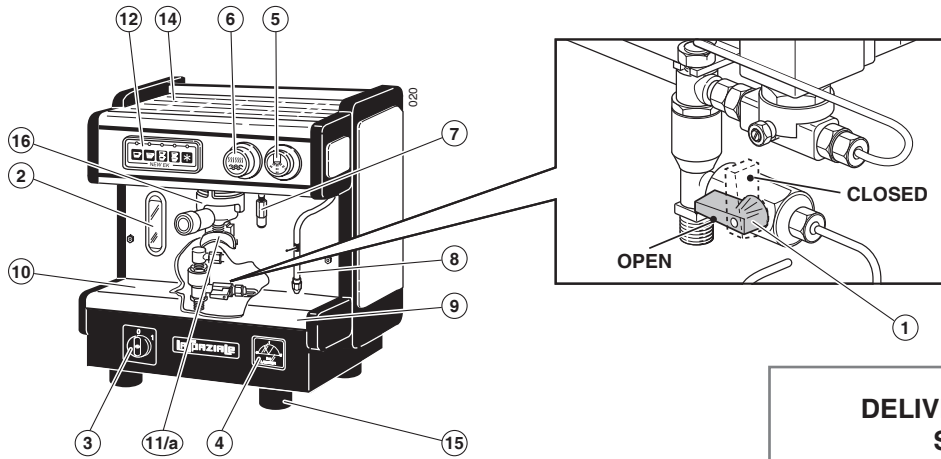

RAPID - SPAZIO

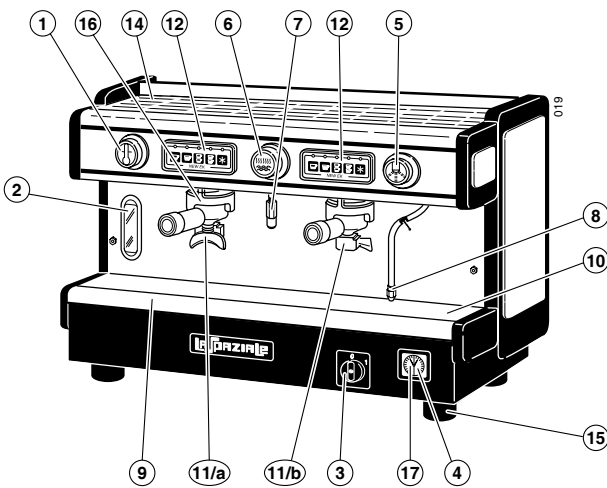

NEW

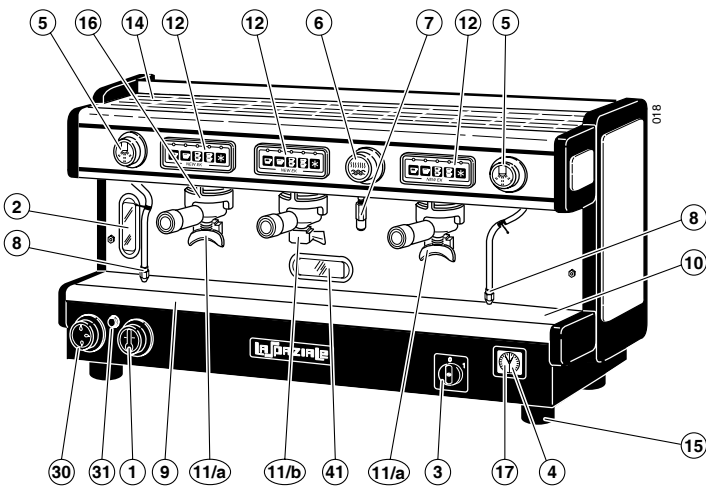

DELIVERY CONTROL SYSTEMS

MOD. EK

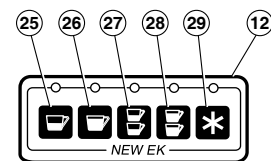

MOD. EC



MOD. 3000

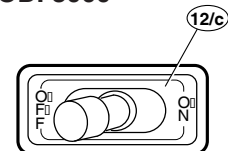

MOD. EP

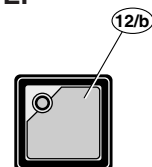

120

**S3 EP**

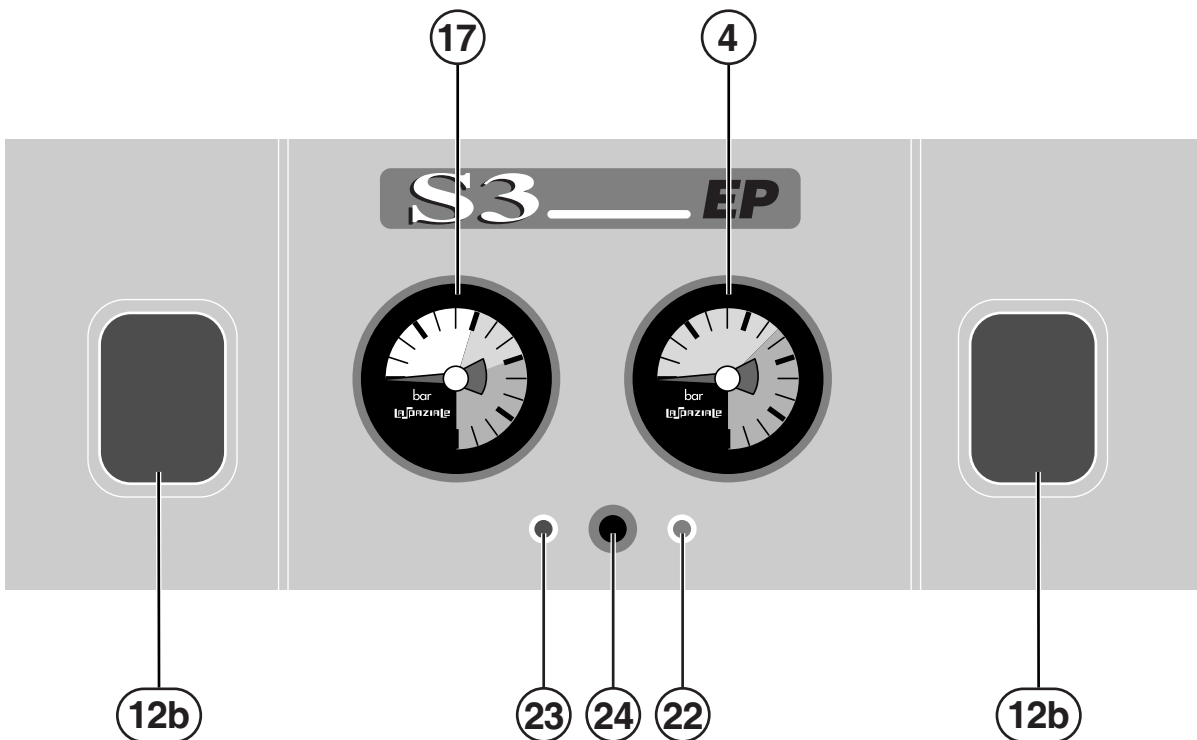
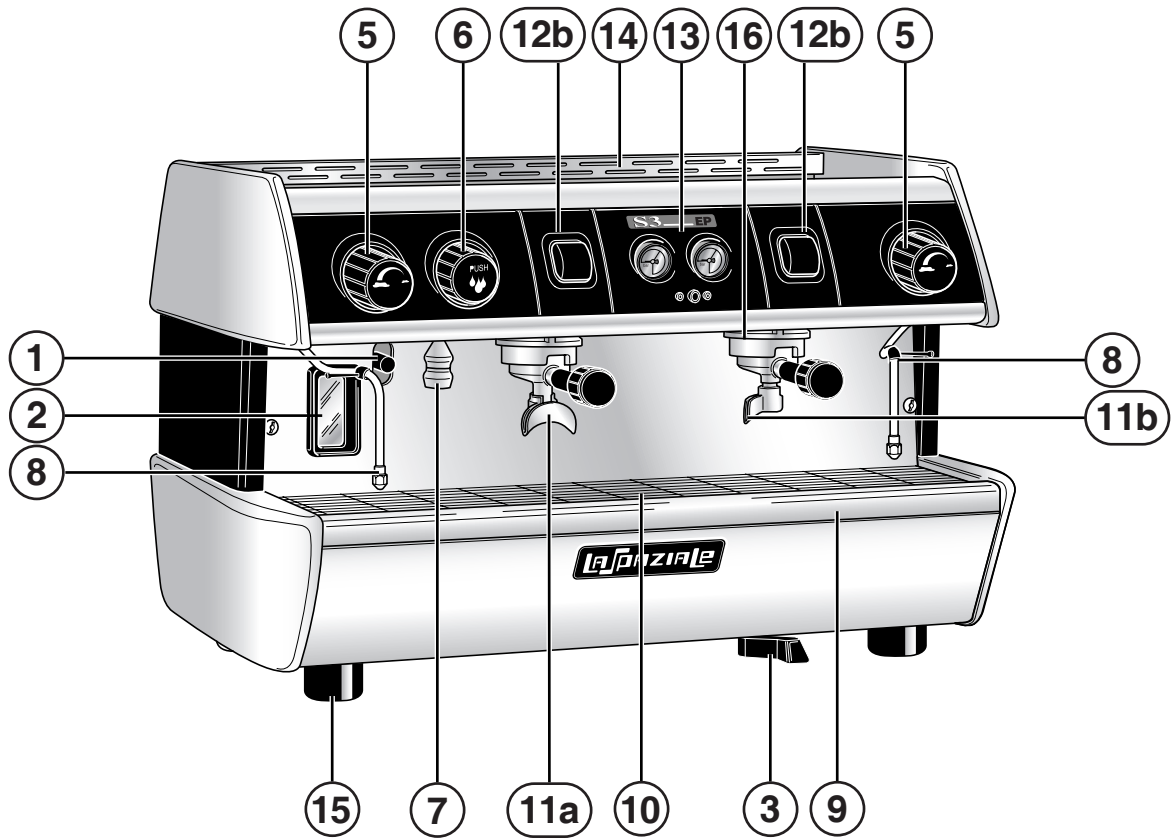

022

S3 EK

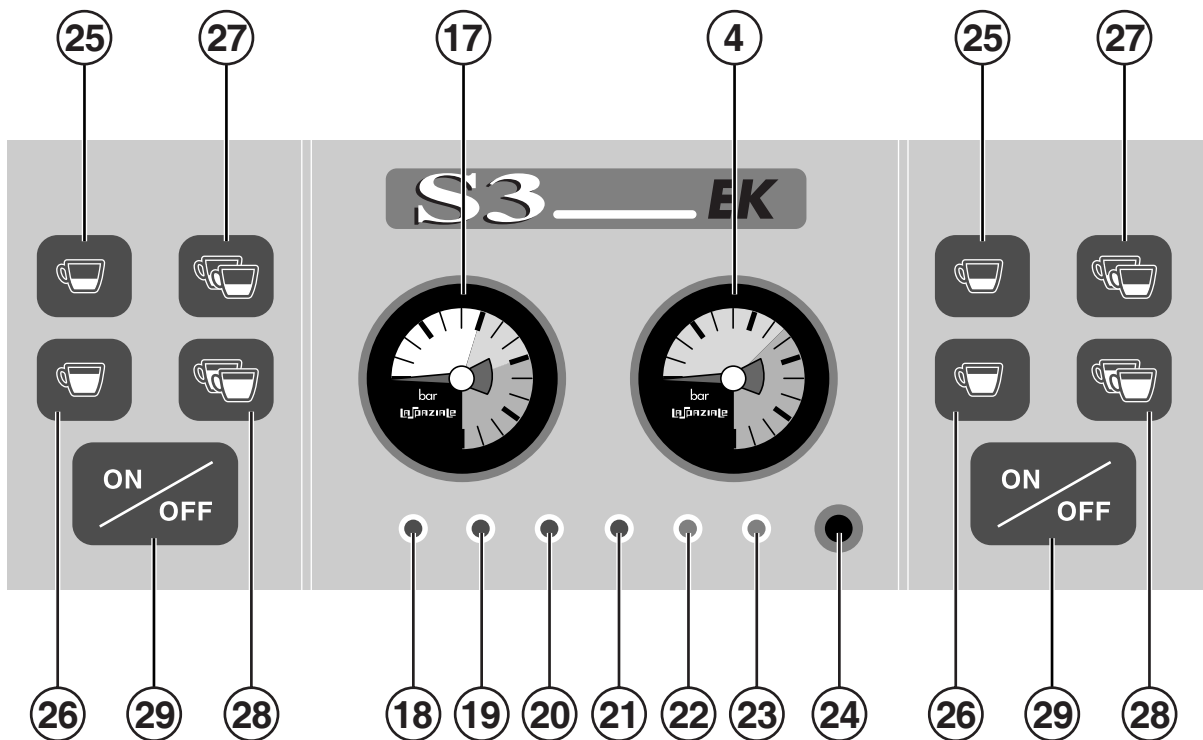
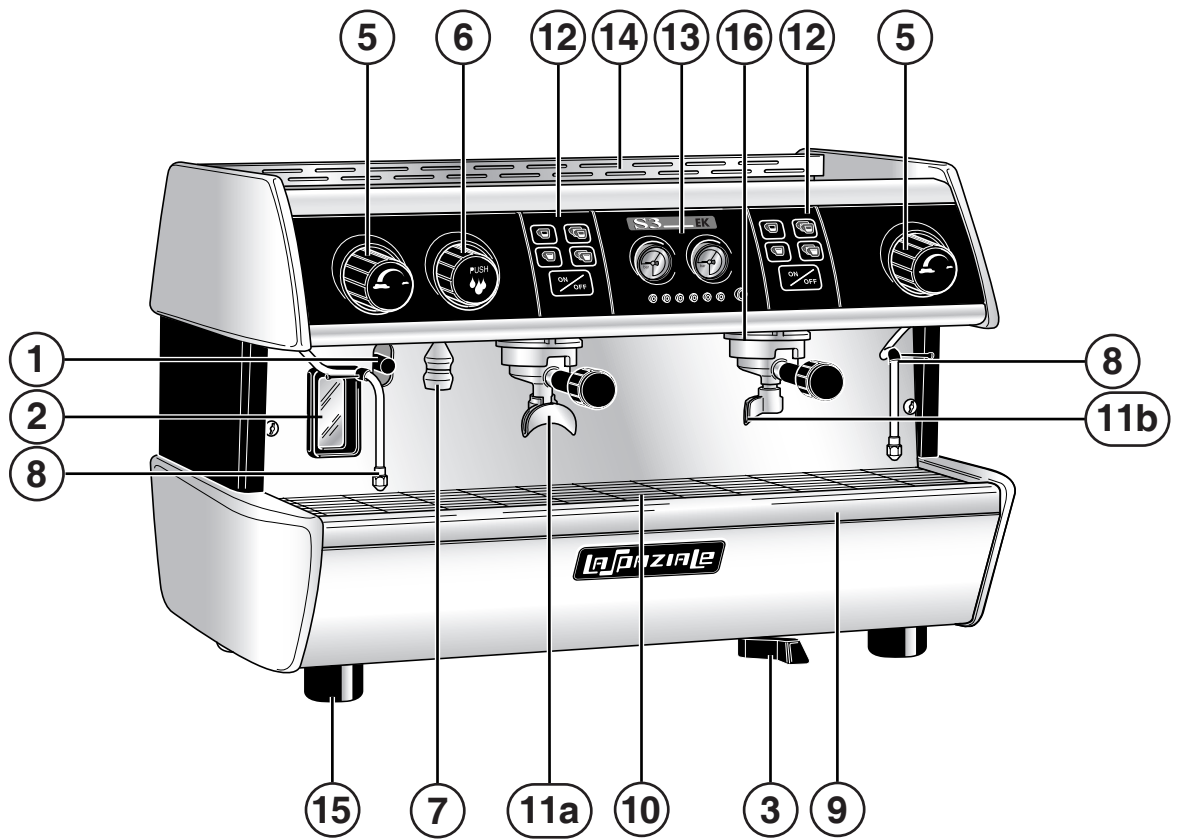

023

S3 Seletron

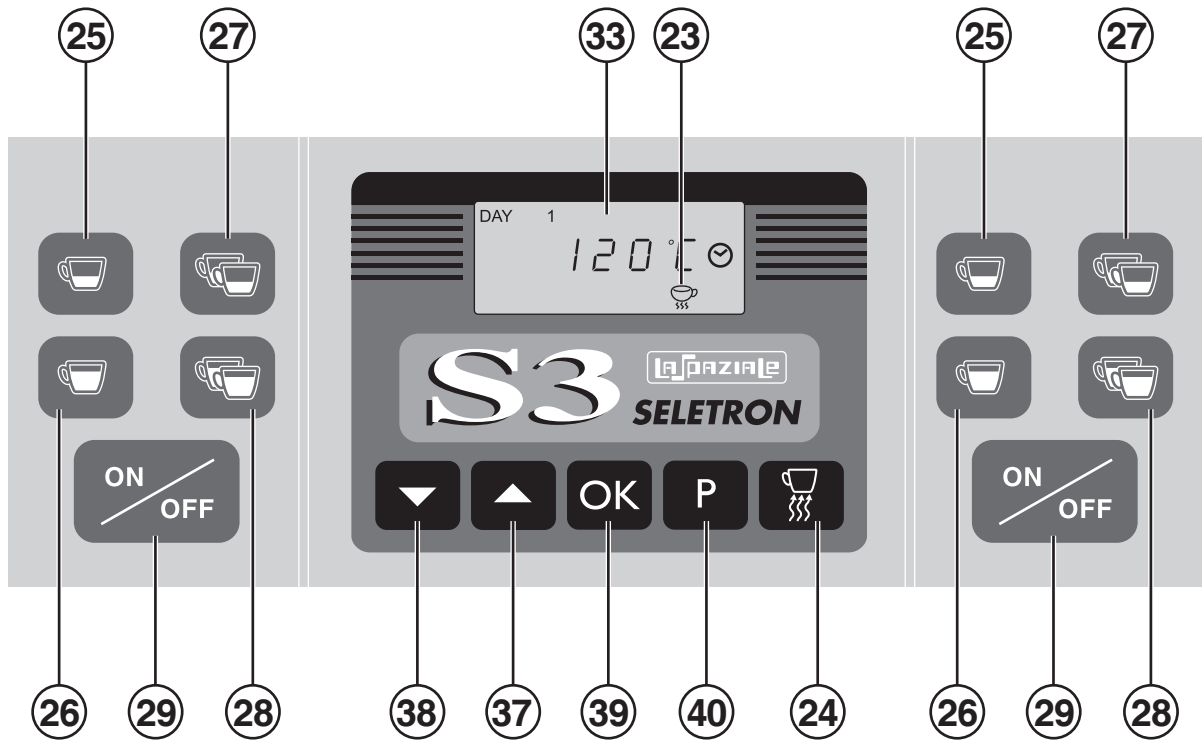
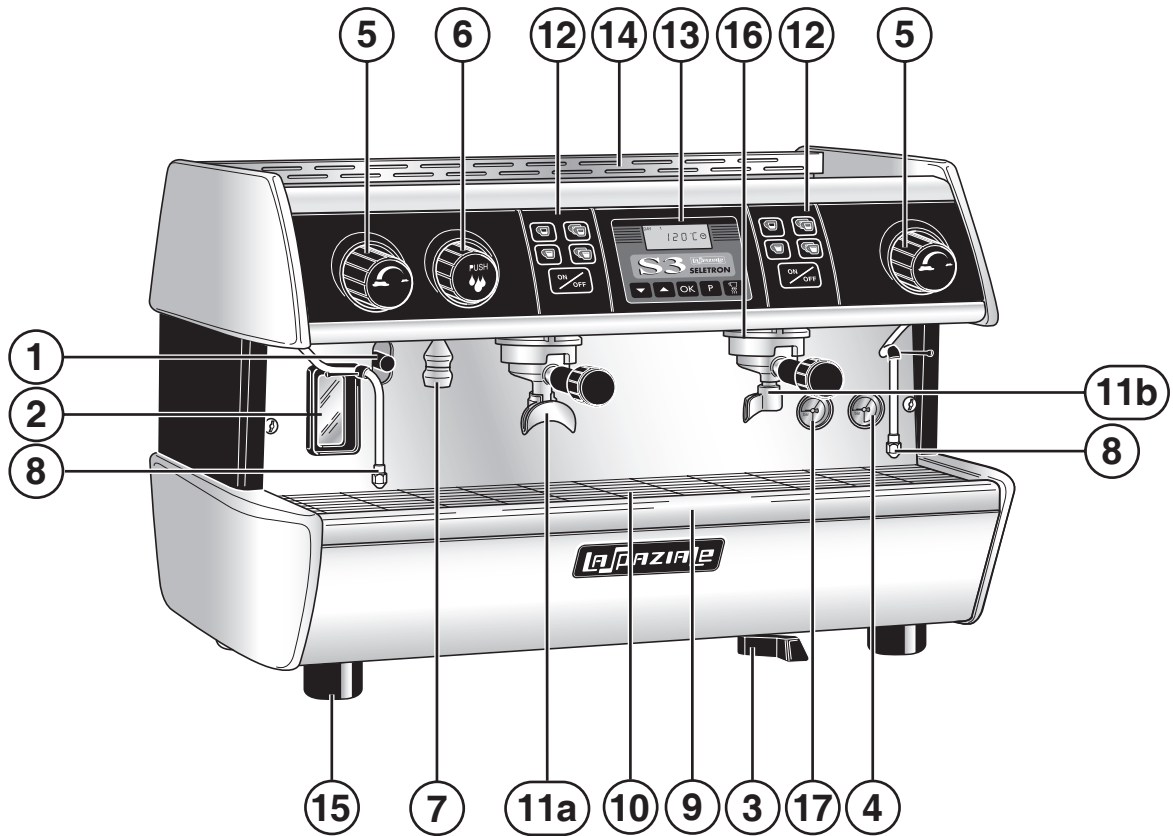

024

S5

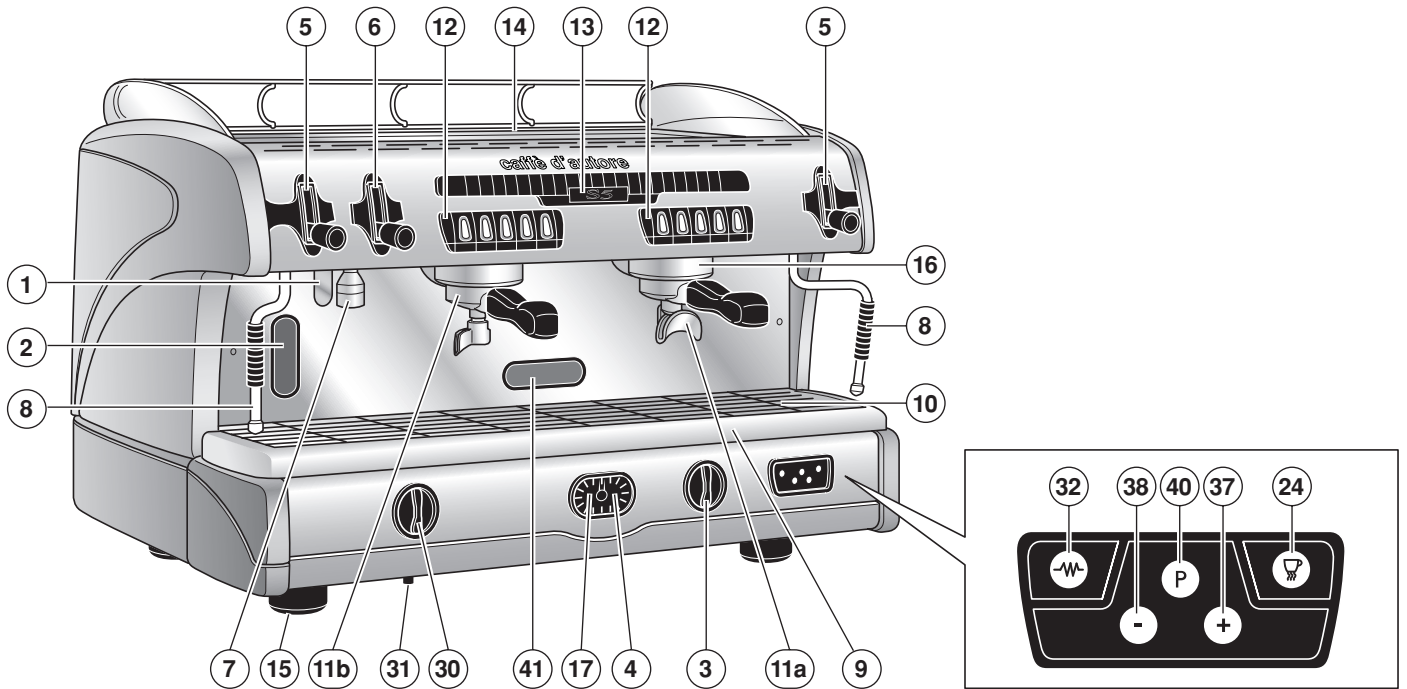

S5 EK

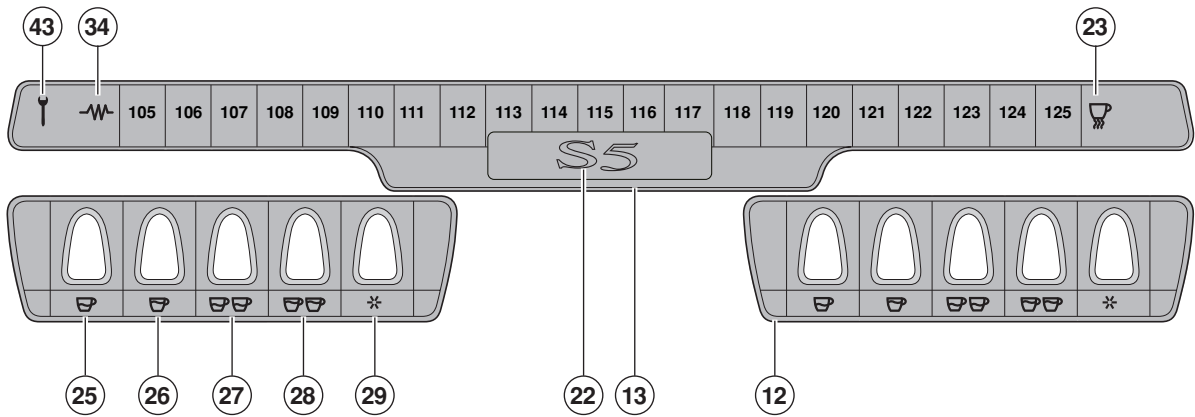

S5 EP

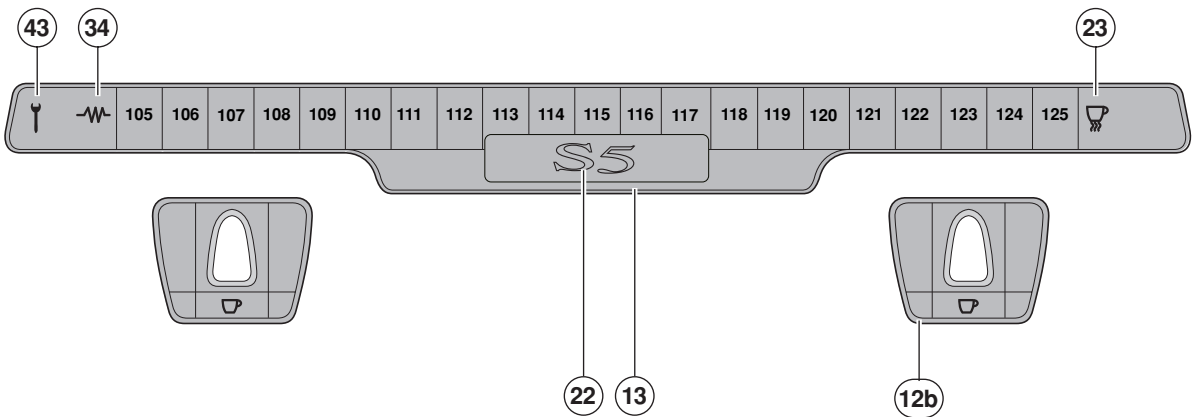

**S5 Water timer version (A.T.)**

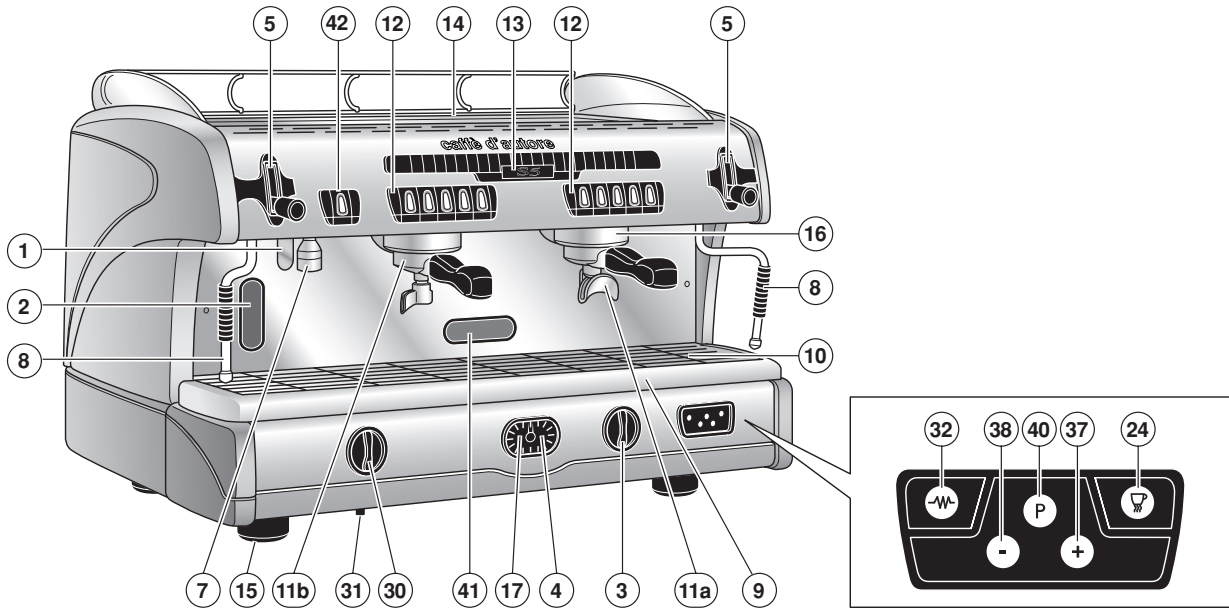

**S5 M.A.T. Version**

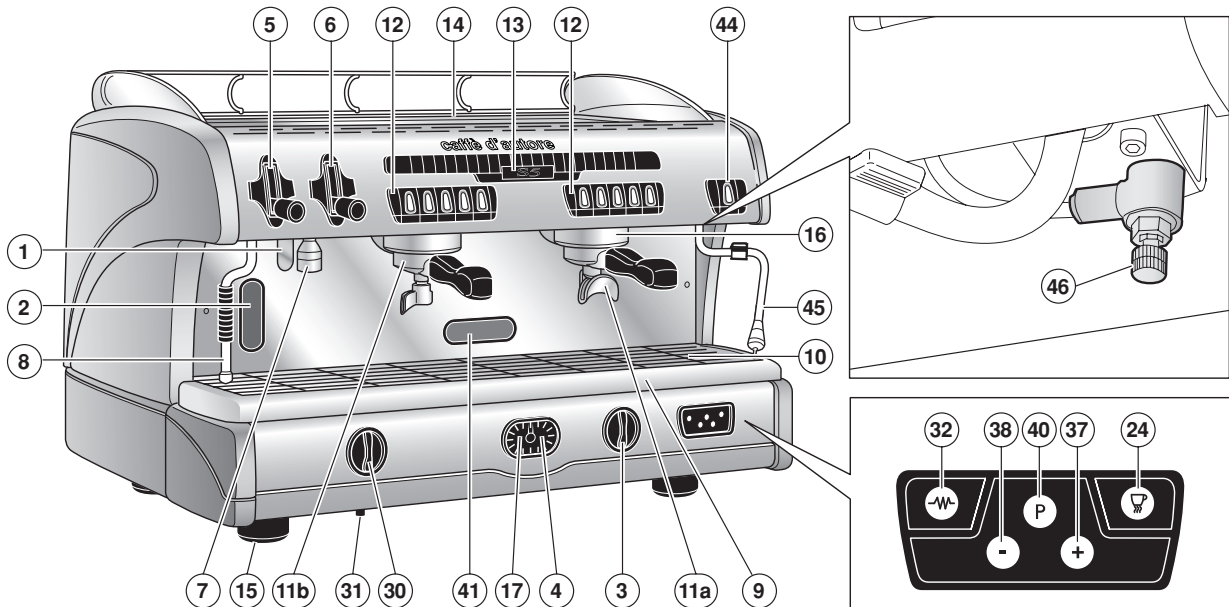



COMPACT and S5 1 GROUP

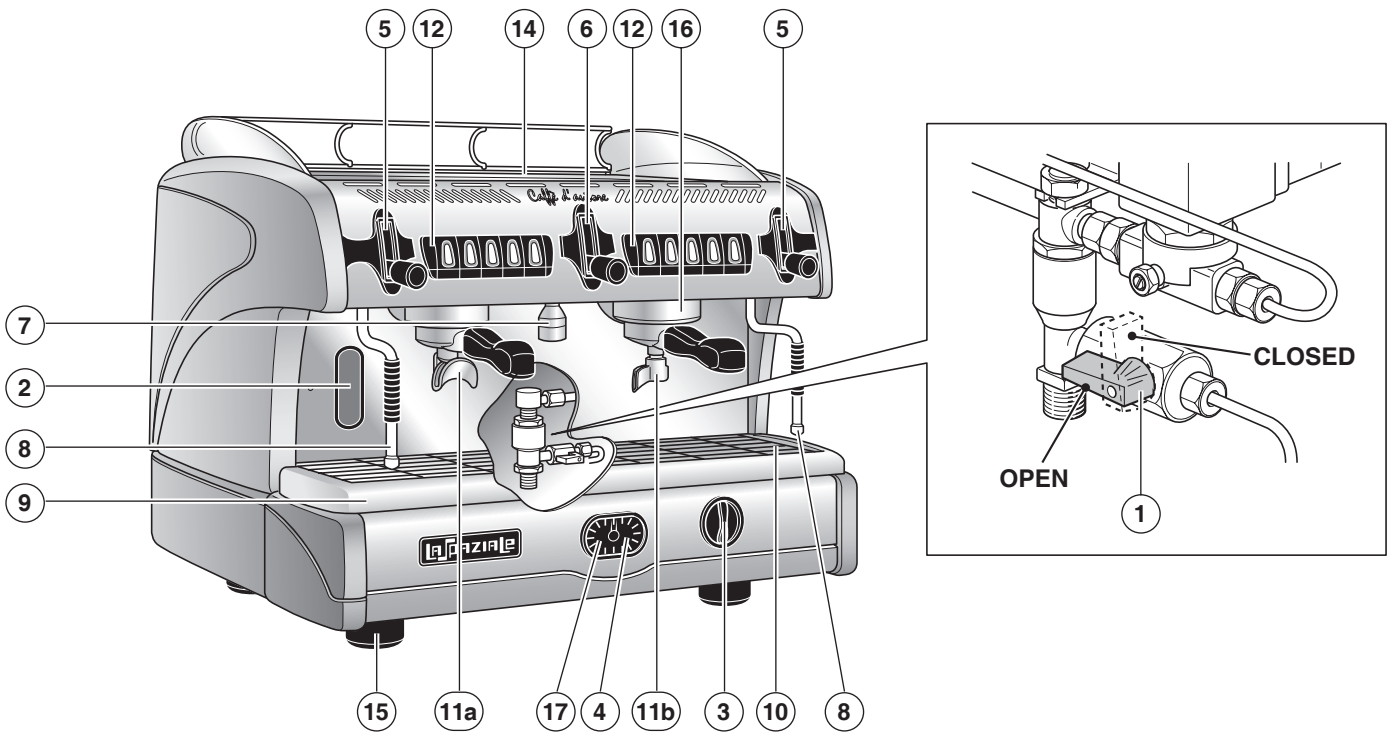

COMPACT EK and S5 EK 1 GROUP

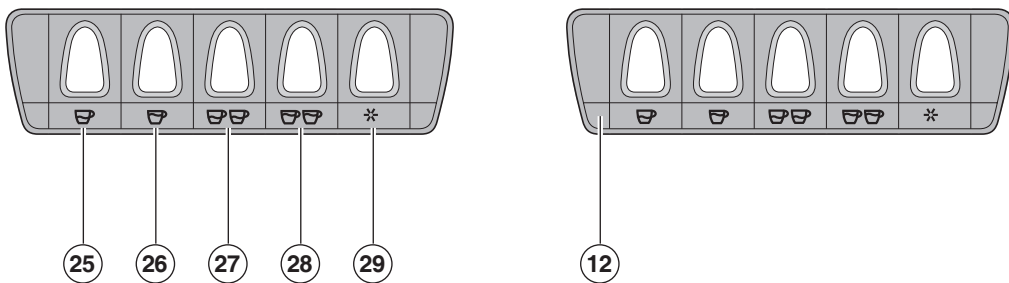

COMPACT EP and S5 EP 1 GROUP



026

**KEY TO PARTS**

- |            |  |           |   |
|------------|--|-----------|---|
| <b>1</b>   | Tap for manual filling valve                           | <b>30</b> | Control knob for gas delivery (optional)                              |
| <b>2</b>   | Boiler water level indicator                           | <b>31</b> | Piezoelectric gas igniter(optional)                                   |
| <b>3</b>   | Main switch  | <b>32</b> | ON/OFF button for appliance electric heating                          |
| <b>4</b>   | Boiler pressure gauge                                  | <b>33</b> | Display   |
| <b>5</b>   | Steam delivery knob                                    | <b>34</b> | Indicator light for electric heating system status                    |
| <b>6</b>   | Hot water dispensing knob                              | <b>37</b> | Display datum increase  |
| <b>7</b>   | Hot water nozzle                                       | <b>38</b> | Display datum decrease  |
| <b>8</b>   | Steam wand   | <b>39</b> | Datum confirm button  |
| <b>9</b>   | Water drip tray  | <b>40</b> | Button to enter programming phase                                     |
| <b>10</b>  | Drip tray grid   | <b>41</b> | Burner inspection opening   |
| <b>11a</b> | 2-cup filter holder                                    | <b>42</b> | Timeed water delivery button -A.T.-(optional)                         |
| <b>11b</b> | 1-cup filter holder                                    | <b>43</b> | Technical assistance indicator (G.A.)                                 |
| <b>12</b>  | Group delivery control with automatic and manual doses | <b>44</b> | Automatic steam delivery button for milk foaming - M.A.T.- (optional) |
| <b>12a</b> | Group delivery control - EC models                     | <b>45</b> | Steam wand with temperature sensor - M.A.T. - (optional)              |
| <b>12b</b> | Group delivery control - EP models                     | <b>46</b> | Air adjustment for milk foaming - M.A.T. - (optional)                 |
| <b>12c</b> | Group delivery control - New 3000 models               |           |   |
| <b>13</b>  | Control panel  |           |   |
| <b>14</b>  | Top cup grid   |           |   |
| <b>15</b>  | Adjustable feet as support of the appliance            |           |   |
| <b>16</b>  | Coffee delivery group                                  |           |   |
| <b>17</b>  | Motor-driven pump pressure gauge                       |           |   |
| <b>18</b>  | Indicator led for 4th group from the right             |           |   |
| <b>19</b>  | Indicator led for 3rd group from the right             |           |   |
| <b>20</b>  | Indicator led for 2nd group from the right             |           |   |
| <b>21</b>  | Indicator led for 1st group from the right             |           |   |
| <b>22</b>  | Control light  |           |   |
| <b>23</b>  | Indicator light for cup warmer status                  |           |   |
| <b>24</b>  | Electric cup warmer operating button                   |           |   |
| <b>25</b>  | 1 short coffee preset delivery button                  |           |   |
| <b>26</b>  | 1 long coffee preset delivery button                   |           |   |
| <b>27</b>  | 2 short coffees preset delivery button                 |           |   |
| <b>28</b>  | 2 long coffees preset delivery button                  |           |   |
| <b>29</b>  | Manual delivery button                                 |           |   |

03/2009



La Spaziale S.p.A.

Via E. Duse, 8  
40033 Casalecchio di Reno  
Bologna - (Italy)  
Tel. +39 051 611.10.11  
Fax +39 051 611.10.40

E-mail: [info@laspaziale.com](mailto:info@laspaziale.com)  
Web Site: [www.laspaziale.com](http://www.laspaziale.com)

Caffè  d'autore